



SMOOTHFLOW[®]

Automated Batch Tunnel Washing Systems

Available in processing classifications
of 100–150 lbs. and 200–220 lbs.
Featuring Braun's Tunnel Infusion Technology[®].



Simple to use touch
screen control panel.

150 LB Shown



U.S.A.

ISO 9001:2015 Certified
(Quality Management System)

All Braun Products are Proudly
Manufactured in the U.S.A.

gabraun.com

SMOOTHFLOW[®] AUTOMATED BATCH TUNNEL WASHING SYSTEMS

New Technology Backed By Science!



All SmoothFlow[®] Series products are built and sourced in the U.S.A. providing for exceptional parts and service support. With Braun you will not be subjected to lengthy lead times for parts and service or made to carry extensive parts inventories.

Braun offers free 24/7 telephone technical support for the life of the equipment!

**Braun 150 Lb.
Batch Tunnel
Washing System
shown**

CUSTOMER DRIVEN - DESIGN PHILOSOPHY

Braun SmoothFlow[®] batch tunnel washer systems are designed and manufactured to provide you with an extremely durable and efficient machine that is easy to operate, simple to maintain, and will provide many years of profitable service.

Due to the simplicity of design, maintenance and reduced parts costs, operators will realize an increase in overall plant productivity and decreased personnel due in part to the minimization of material handling. The laundry facility will also see the opportunity to grow its business by taking on additional capacity.

This unique design eliminates the necessity for the cumbersome maintenance-intensive double-drum system.

As a result, there is a very limited amount of moving parts and therefore, the cost of maintaining the Braun batch tunnel washer is lower than tunnels with the double-drum design.

WASHING CAPABILITY/ MULTIPLE APPLICATIONS

Braun's batch tunnel washers are designed for high-volume laundry environments and surpass many of today's over-engineered tunnel systems in terms of reliability, maintenance and efficiency.

Braun tunnel systems applications include healthcare, hospitality linen products, commercial and industrial linen rental, and scour bleach processing.



**Braun 220Lb.
Batch Tunnel
Washing System
shown**

Braun tunnels can process classifications from light to heavy industrial soiled textiles and can produce stain-free hygienically clean healthcare linens.

SmoothFlow® tunnels operate with the mechanics of an open helicoid process NOT an archimedial screw. Each chamber washes with a similar level of mechanical action as that of a conventional Open Pocket Washer without the limitations imposed by transfer scoops. This provides for exceptional wash quality and a highly efficient process. The archimedial screw process used by other manufacturers causes goods to move forward and back causing potential roping and transfer problems and reduces the efficiency of the wash process.

- The mono-shell open helicoid tube design affords the mechanical action and perpetual cleaning of the wash cylinder.
- Braun's non-porous stainless steel tub, tanks and process piping minimize the growth of biofilms.

- No stagnant bath or outer drum surfaces which can become incubation chambers for microbial growth.
- Tunnel Infusion Technology® - Braun's tunnel infusion technology is used throughout the tunnel. This is Braun's trademarked fill process technology of adding water and chemistry above the goods providing superior agitation and mixing.
- **NO ROPING OR PLUGGING!**
Safety – Monoshell helicoid features a large opening in which the diameter is balanced with the chamber length. This, and the unique friction drive system eliminates the need for access hatches and operator entry into the processing vessel. This eliminates significant safety concerns that put an employee into a confined space when clearing a roping and plugging situation.
- **Energy** – Our standard systems afford the ability to support low and high temperature chemistries with limited energy consumption. We also offer a steam generator package to avoid the costs associated with boiler rooms and stationary engineers.
- **Water Efficiency** – Exceptional wash pie balance associated with Braun tunnels allow for low water consumption (.4 to .7 gallons/lb., depending on soil type), while affording extremely low rewash rates (2% or less). This is not only efficient, but it improves linen life. All water used in the process is reused at least three times in the process!

***All Braun performance data is collected at client locations
in real operating conditions!***

EFFECTIVE COUNTERFLOW IS KEY TO SYSTEM EFFICIENCY

BATCH TUNNEL WASHER PROCESSING

Braun accomplishes counterflow inside the machine through the compartment walls, which eliminates inside seals that are difficult to monitor and service. Counterflow occurs in both the wash and rinse zones. Within each zone, the lower half of the compartment walls are perforated to enable water to counterflow through the goods enhancing the wash process and allowing maximum recovery and reuse of water, chemicals and energy.

Between zones, solid compartment walls keep all wash solutions separated. In the normal standby and transfer positions, total separation exists between batches and 100% batch integrity is assured. This direct method of chamber control eliminates the need for redirecting and pumping water outside the body of the machine through pipes and weir boxes, where the solution is not able to perform its function as efficiently as direct counterflow.

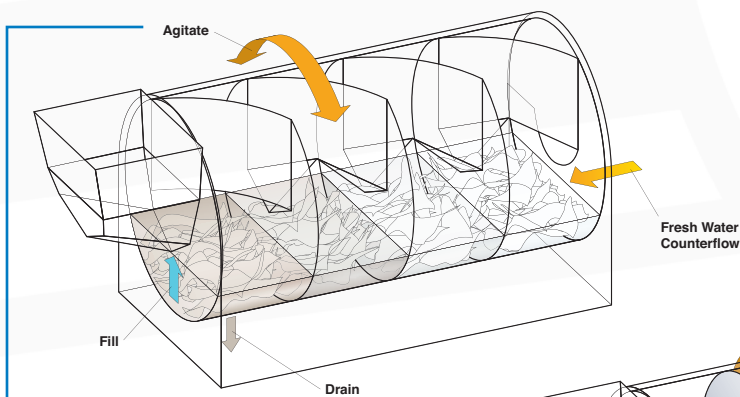

Washing and rinsing counterflow positive transfer method

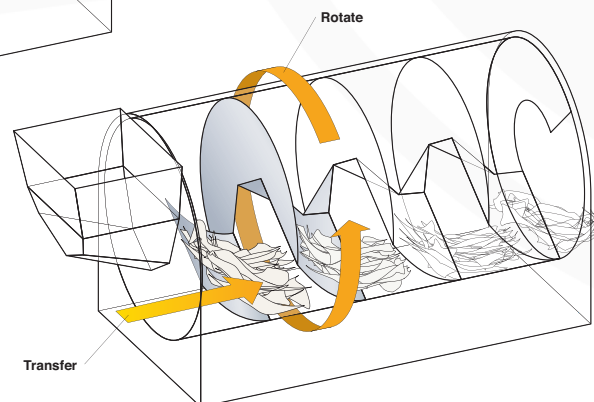

BATH EXCHANGE

Braun Batch Tunnel Washers feature bath exchange compartments. Each has a rapid drain, programmable to a preset time.

This provides flexibility in processing a range of soil classifications. All bath exchanges offer programmable refills after the rapid drain is completed. Additionally, there are up to three drain and fill events programmable for each cycle.

TEMPERATURE CONTROL SYSTEM

External tank and inline steam injection allow heating to be accomplished without steam injection fittings directly attached to the tunnel drum.

Note: There are also direct injection sparge tubes in both the wash and finish zones in Braun 150 and 220 lb. Tunnels.

Sparge tube heating puts heat directly at the source versus heating process water in an outer drum. The process is therefore energy efficient and ultimately saves operating costs.

Braun's process of counter flow is proven! This, coupled with the design characteristics of the Smoothflow Tunnels provides exceptional wash quality, overall system efficiency, and an inexpensive operating environment.

ENERGY AND WATER CONSERVATION

WATER RECOVERY AND REUSE SYSTEM

Braun Batch Tunnel Washer's water recovery and reuse systems ensure all possible process water is captured and recycled throughout the entire machine.

This includes:

- Hydraulic cooling water from the press
- All press water is re-used as either rinse, or in the pre-wash of the machine.
- Recovery of water from seal wetting and unintended overflow to the rinse reclaim tanks.
- Every stream in the Braun Tunnel is reused at least three times in the process!

WATER USAGE

The water usage range is .4 – .7 gallons per pound of dry linen depending on the soil classification and goods being processed.

Note: The water usage claims in gallons per pound of dry linen is the total water consumption for the entire system.

HEATING SYSTEM EFFICIENCY

Batch Tunnel Washer heating systems are energy efficient as heated process streams are reused throughout the machine allowing precious BTU's to be conserved. Steady state steam usage is below 0.6 pounds of steam per pound of dry linen in a high temperature healthcare peroxide wash process. The steam usage range is 0.4–0.75 pounds of steam per pound of dry linen depending on process temperatures run through the entire machine.

KEY FEATURES:

- Proven ability to wash most every product processed in the laundry industry
- Dependable proven track record
- Single-drum design eliminates cumbersome maintenance as with double-drum systems
- Single drum, coupled with our bottom transfer process, allows for maximum utilization of the machine's processing capacity without the fear of roping or plugging.
- Contoured and welded inner walls for strength and positive transfer
- Friction drive eliminates chains and belts
- Easy to replace motor — can be changed without having to change gear box
- Four motors — will run on three if one should fail
- Easy-to-replace rubber seals allow water in, chemical injection and water out
- Flexible and simple-to-use controls
- Allows for an efficient processing environment
- Minimizes linen replacement and downtime costs
- Optimum productivity and operational reliability
- Minimal total overall processing and operating costs
- Can be mounted on curb or jack stands
- Can be loaded with pocket loader or by rail

All Braun performance data is collected at client locations in real operating conditions!

130 LB. TUNNEL FEATURES

Drive System

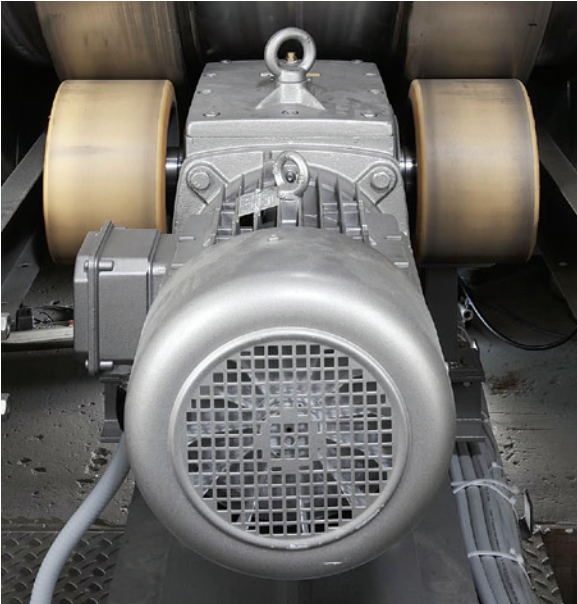

The drive system of the Braun tunnel washer is simple, rugged and reliable. There are no chains or belts to stretch and break, no sprockets that wear.

Heating–Steam Valves



Unique to the Braun tunnel, the external heating source eliminates direct contact of steam to the goods. This assures the quality of the process.

150 LB. & 220 LB. TUNNEL FEATURES

DRIVE SYSTEM

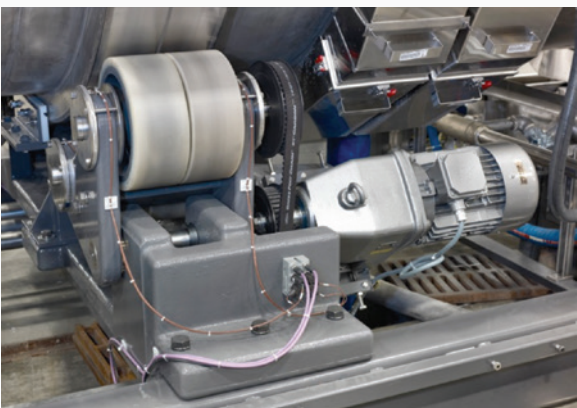

The drive system of the Braun Tunnel Washer is simple, rugged and reliable. There are no chains that may wear or break. The four drive motors are readily accessible and provide an error-free friction drive system.

WATER RECOVERY



In addition to a well designed reuse system, Braun Tunnels feature excess water collection capability for superior water reuse efficiency.

150 LB. & 220 LB. TUNNEL FEATURES (CONTINUED)

MAIN WASH FLOW



The wash flow system has both an inductive flow sensor and precision flow control valve to control the flow to the wash zone.

CHEMICAL AND WATER INJECTION



Water and chemistry are injected at this location with the chemistry added above the water level for proper and thorough mixing.

HEATING SYSTEMS

The heating system on the Braun BTW is designed for the application of steam to the machine in three different ways. Each of the heat applications on the machine are designed for the highest energy efficiency conversion, as well as for the quickest ramp up to operating temperature. The methods of heating are noted below including heating applications of each method:



IN-TANK HEATING (STEAM INJECTORS)

- utilized for heating reclaimed water in the wetout tank and final rinse reclaim tank
- heating system sized to meet all industry demands
- energy efficient direct steam tank injection
- temperature probe in tanks for indication feedback
- precision temperature control



IN-LINE HEATING (STEAM RING)

- utilized for heating all prewash compartments and main wash flow can be used for supplemental or primary heating of prewash compartments
- primary heating for main wash flow
- energy efficient direct steam line injection in process line while fluid being transferred
- temperature probe in pipelines for indication feedback
- precision temperature control

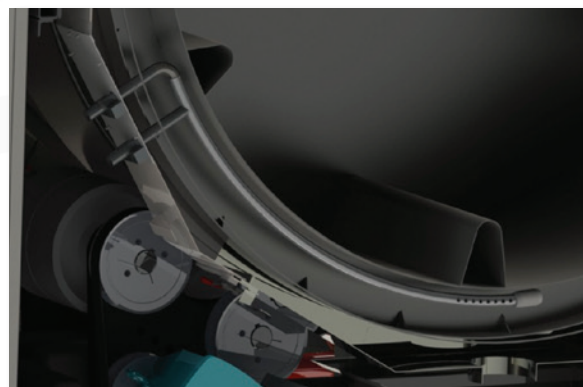

IN-SHELL HEATING

- patent pending technology
- utilized for heating all necessary wash compartments
- energy efficient direct steam injection in BTW cylinder to get direct delivery of heat to process
- temperature probe in shell for indication feedback
- precision temperature control
- provides heating capability in one finish compartment for improved extraction and/or starch applications

SMOOTHFLOW® SINGLE-STAGE BATCH EXTRACTION PRESS 130, 150 & 220 BPE



SmoothFlow

Features a quick cycle time with adjustable pressure ramp rates to obtain maximum pressure in a short time if desired.

Braun SmoothFlow Single-stage Batch Extraction Presses are manufactured for 100% cotton, polyester/cotton-blended fabrics, 100% synthetics, and special textile items such as incontinence pads.

Additional specialty items that can be processed are membrane fabrics for surgical applications and clean rooms such as GORE-TEX®, and mops.

PRECISION-CONTOURED MATERIALS OF CONSTRUCTION

With the SmoothFlow Press, all metal surfaces that contact the goods are made of 304 stainless steel, and all non-stainless steel parts are either plated with electroless nickel or painted for superior corrosion resistance..

KEY FEATURES

- Configurable tamping options
- Engineered base plate for optimal water removal
- Flexible and simple-to-use controls
- State-of-the-art PLC with touch screen
- Domestically supplied water-cooled hydraulics
- Extensive use of data-management tools through WASHNET®
- Circumferential & bottom perforations on solid stainless steel basket and belting allow enhanced water extraction
- Precision-contoured materials of construction: 304 stainless steel, chute and basket
- Ductile iron castings



PRESS MEMBRANE

- White color ensures no marks on goods
- Membrane built to last and offered with waterless disks for further life after being cut
- Built-in retaining ring significantly shortens change out times
- Unique pattern on bottom reduces potential for cakes to stick
- Available for water-fill and waterless-fill

SMOOTHFLOW® AUTOMATED SHUTTLE SYSTEMS ESHNF



The automated delivery system can include single or multiple elevating shuttles, or a combination of separate stationary elevators and traveling shuttles, depending upon individual needs.

SMOOTH, ERROR-FREE TRANSFER OF GOODS

The flexibility of Braun material handling systems greatly affects washroom labor requirements. The ergonomics of loading and unloading Braun tunnels and dryers is greatly enhanced. Braun's inverter driven smart shuttle systems basically eliminate much of the heavy work, providing a safe, smooth, error-free, and complete transfer of goods.

▶ Tape switch safety guards are standard on all Braun Automated Shuttles and comply with all regulatory requirements.

Braun Material Handling Systems

Store and transport extracted cakes from the extraction press to the dryer, and convey dried textiles to finishing and sorting areas, meeting the demands of any plant layout.



SMOOTHFLOW® PBS AUTOMATED DRYERS



Braun 300 PBS
Side-by-Side
Non Chute Load
Dryers

Braun PBS Dryers are available in 300-400 lb. and 500-600 lb. clean dry weight processing capacities (gas or steam). Utilizing a linear heat source, Braun Dryers provide evenly distributed heat along the full length of the dryer basket ensuring even, efficient drying. The computerized controls are fully programmable, and completely self-diagnostic, and they continually make precise adjustments to keep the dryer environment at the programmed temperature.

KEY DESIGN FEATURES

All doors, basket ribs and basket perforated panels are made of 304 stainless steel. All basket panels are removable and can be supplied with various coatings. The on-board lint collection screens are automatically blown down with air knives and the lint is removed via a central vacuum system at the beginning of each dry cycle.

EASE OF MAINTENANCE

The SmoothFlow Series Dryer faceplates are hinged so that they can swing out from the dryer shell in either direction to allow access to the basket seal or basket for maintenance without rigging.

SMOOTHFLOW® PBS AUTOMATED DRYERS (CONTINUED)

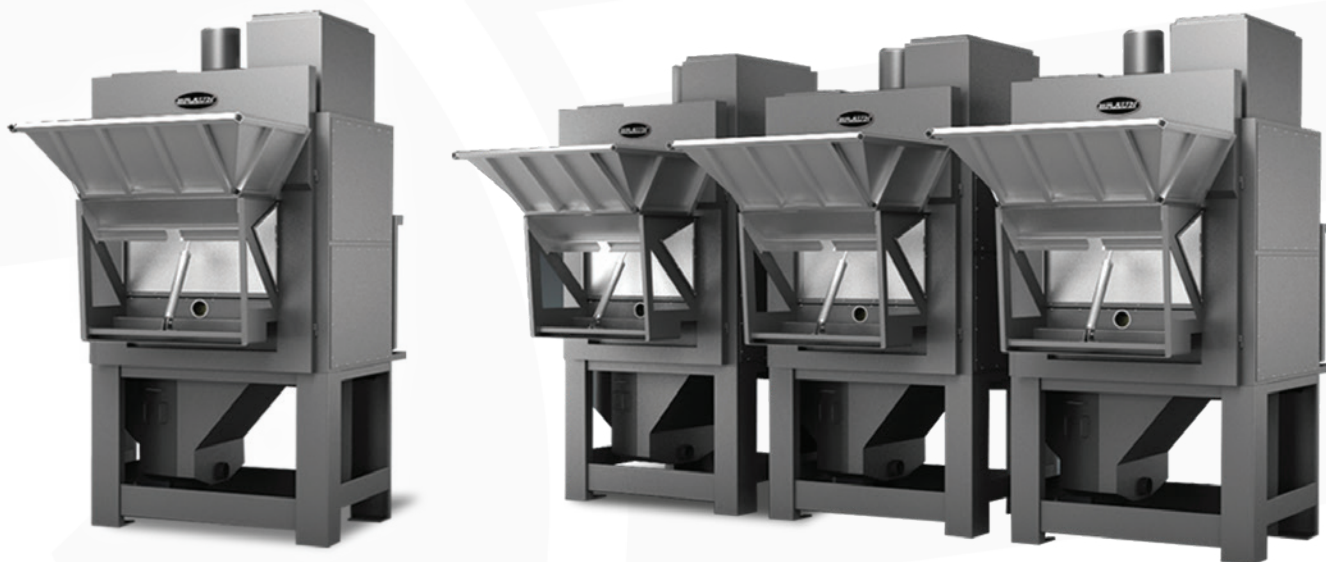

300 PBS Chute Load Dryer

*Shown here are single
and side-by-side chute
load configurations.*

KEY FEATURES

- No-tilt pass-thru design — fewer moving parts
- Microprocessor-controlled modulating gas valve — maintains basket temperatures accurately throughout the entire drying cycle
- Line-style gas burner with a combustion air blower — does not require a combustion filter
- Computerized controls are fully programmable and completely self-diagnostic
- Continually makes precise adjustments to keep the dryer environment at the programmed temperature
- Central lint vacuum system
- Designed for easy access to all components to simplify maintenance (hinged face plates, access panels on basket, drive, doors and seals)
- The PBS Dryer is available in a patent-pending chute load design as well as a side-by-side chute load configuration. The side-by-side configuration requires no spacing between with each set of dryers. All dryers are identical, minimizing the number of spare parts needed and maximizing floor space.

PT SERIES DRYERS



CHUTE LOAD

PT Dryers can also be ordered in a chute load configuration. The chute loading system eliminates shuttle transfer of goods. In this system, sling bags are dropped into the dryer for processing. There is no limitation on goods types in this particular system, therefore providing for great flexibility with respect to washroom configuration.



Braun PT Series Dryers

Are the most advanced, efficient and compact dryers available today.

Braun PT Dryers are available in 300-400, 500-600, and 700-800 lb. clean dry weight processing capacities. (Gas or Steam)

FULLY MODULATING, COMPUTER CONTROLLED HEATING

Full burner modulation results in precise basket chamber temperature control, yields fast dry times, consistent quality and outstanding resource efficiency. Monitoring both inlet and outlet temperatures, the Braun Dryer control precisely meters the fuel, constantly trimming the amount used, throughout the drying cycle. As the water content in the load decreases, the amount of fuel needed to maintain the programmed temperature decreases.

COAXIAL DUCTING

Braun PT Dryers use coaxial ducting to increase efficiency. Unlike a re-circulation duct system, the hot internal coaxial exhaust duct transfers only the heat energy to the cold incoming air, sending the now cooler, moisture laden air outside. A less efficient re-circulation duct system dumps the moisture that you are trying to drive off, back into the goods.

The pre-heated air created by the coaxial ducting decreases the amount of fuel required to heat the basket chamber to the final operating temperature. This way you get a monetary return from the money spent to heat the air in the first place. Another advantage of coaxial ducting is a significant reduction in operation sound levels as well as a single roof penetration.

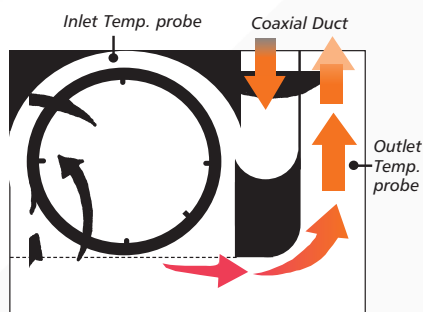

Coaxial Ducting

Transfers only the heat energy to the cold incoming air, sending the now cooler, moisture laden air outside.

PRECISION BURNER CONTROL

Inlet and exhaust temperature graphs show how constant monitoring of temperatures combine with precision burner modulation to maximize efficiency and eliminate variations in basket temperatures. The inlet temperature rises rapidly as incoming air is heated to the desired basket temperature. This drops off as hot exhaust air pre-heats inlet air, requiring less energy to reach constant basket temperatures. The exhaust graph represents basket temperature, which rises to the desired temperature and remains consistent throughout the entire dry cycle.

LINEAR HEAT SOURCE

While some dryers use a ring design burner, Braun dryers incorporate a unique application of a linear burner for their heat source. This design feature further ensures that the heat will be evenly distributed within the full volume of the dryer basket, further maximizing fuel conservation and productivity.

LOW NOX BURNER TECHNOLOGY

Braun PT Dryers are available with a Low Nitrogen Oxide (NOx) burner. These dryers are true low NOx qualified, and third-party testing in California for low NOx compliance.

An independent third-party testing confirmed Braun is over 90% cleaner than the minimum compliance required by West Coast Air-quality Board Standards¹ for NOx emissions. * Confirmed testing averaged 2.2 ppm an 0.12 lbs./hr. NOx from the Braun dryer.

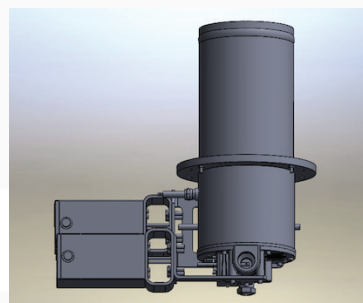

Note: The maximum allowable emissions of Nitrogen Oxide are 30 ppm. The third-party testing results indicate that Braun dryers are sure to meet any low NOx emission requirement.

The numbers obtained during third party testing are for dryer process combustion emissions only. Processing goods containing VOC's will add to the total dryer combustion emissions measured and may cause the measured emissions to exceed the AQB allowable NOx emission standard.

OTHER FEATURES

- **Full body insulation** for increased thermal efficiency and a more temperate workplace
- **Touchscreen Dryer control** with 50-formula capability
- **Integrates easily** into a fully automated Open Pocket or Batch Tunnel Washer system
- **Enhanced Functions** with Braun's Data Management System
- **Optional coated baskets available**
- **Sleek Exterior** allows for easy cleaning to improve the appearance, cleanliness, and safety of your facility
- **Removable stainless steel basket panels**
- **Ethernet ready**
- **Air tight drying vessel**

SPECIFICATIONS

Please see your Braun representative for specifics based on your desired model and configuration.

WASHNET® HMI/SCADA SOFTWARE SOLUTION



EQUIPMENT STATUS AND PERFORMANCE REPORT CAPABILITIES

- Customized screens and reports
- Exceptional access to real-time performance metrics and machine status
- Unlimited data query capabilities for performance analysis
- Daily production totals available per machine
- Alarms displayed in simple, meaningful text

CENTRALIZED FORMULA MANAGEMENT

- Formula programming
- Download formulas and machine configurations

DECISION SUPPORT SOFTWARE FEATURES

- Fully integrated system data accumulation
- Automatic import of data from all networked equipment
- SQL database using standard ODBC drivers
- Complete system tracking
- Numerous production reports available:
 - By time, date, shift
 - By formula and machine number
 - By alarm type

Note: Braun has a staff of hardware and software developers dedicated to supporting Washnet and its solutions platforms.

WASHNET®

helps in the planning and controlling of the most efficient and effective laundry operation.

SmoothFlow Series Tunnel Systems also feature Braun's WASHNET® HMI/SCADA software solution. WASHNET provides plant operators access to real time data so that they can make timely decisions proactively. Operators can monitor equipment, manage formulas, and view equipment alarm and production history. WASHNET also allows Braun technicians the ability to remotely support the technical needs of the operator. This is an exceptionally powerful tool designed to allow operation managers to optimize site performance through the use of real time data.

HMI/SCADA SOFTWARE SOLUTION (GENERAL)

- Windows compatible
- Three levels of password protection

CUSTOMER SUPPORT



PROJECT MANAGEMENT

Braun's project management team consists of CAD designers, sales veterans, office support staff, and engineers. The project management team ensures every project is on time, on budget and meets customer expectations. They use a system of checks and balances designed to streamline and simplify every aspect of sales and production.

The Braun team works directly with our customers to develop the project scope of work and installation timeline and to define training needs. They coordinate with contractors, other equipment manufacturers, and service technicians to see that equipment installations go smoothly and are properly executed. Braun will draw up floor plans to specifications, interface with engineers on major projects, schedule deliveries, and supervise installations.

PARTS SUPPORT

Braun's parts support specialists are available to help you during our regular operating hours from 8 a.m. to 6 p.m. EST. Please call (800) 432-7286, and Dial 1. You may also visit our Web site at gabraun.com and register to order parts online.

SERVICE SUPPORT HELP DESK

Braun offers customers free technical support 24 hours a day, 7 days a week through our help desk. This gives customers direct contact with our highly trained technical staff.

Braun's Help Desk Plus feature is an interactive visual assist system which allows customers to interact with our help desk team virtually via cell phone or tablet*. This service is available during regular service support hours.

REGULAR SERVICE SUPPORT HOURS

8:00 a.m. – 5:00 p.m. EST
(800) 432-7286, Dial 2

AFTER BUSINESS HOURS AND EMERGENCY/WEEKEND

(800) 432-7286, Dial 400

SERVICE SCHOOLS AND WELLNESS PROGRAMS

General Service Schools

All of Braun's service schools are conducted within our manufacturing facilities. These courses are for those individuals responsible for the short – and long-term care of Braun laundry equipment. The objective is to assist your staff in developing maintenance proficiency and self-sufficiency to protect your investment in Braun equipment.



Custom Service Schools

Braun will travel to your laundry facility and train your staff on equipment function and required maintenance. These training sessions, which will be tailored to your specific needs and equipment density, will combine hands-on demonstrations and classroom discussions.

Site Wellness Programs

With Braun wellness programs, a certified Braun technician visits the site and evaluates the state of the equipment and controls. This evaluation documents, with pictures, the parts, software, and labor required to bring the equipment back to an effective and efficient state. An implementation plan is then reviewed and enacted. The goal of the wellness program is to create a relationship that enables our customer's maintenance team and the Braun service team to work together to keep Braun equipment productive for years to come. This service is designed to augment our customer's captive maintenance program.

For more information regarding Braun customer support programs, please contact our field service coordinator at (800) 432-7286 x 237 or visit our Web site at gabraun.com.

SPECIFICATIONS

For detailed equipment specifications please consult with your Braun Regional Sales Manager or contact us by email at equipmentspecifications@gabraun.com



ISO 9001:2015 CERTIFIED
(Quality Management System)

G.A. Braun, Inc.
79 General Irwin Boulevard
N. Syracuse, NY 13212

Mail to:
P.O. Box 3029
Syracuse, NY 13220-3029

Phone
1-800-432-7286

Fax
(315) 475-4130

Parts Help Desk
1-800-432-7286 X 1

Service Help Desk
1-800-432-7286 X 2



U.S.A.

All Braun Products are Proudly
Manufactured in the U.S.A.